

CSE220 Practice Problems

Boolean Algebra

1. Prove the following Boolean expression using algebra.

- A. $X'Y' + X'Y + XY = X' + Y$
- B. $A'B + B'C' + AB + B'C = 1$
- C. $Y + X'Z + XY' = X + Y + Z$
- D. $X'Y' + Y'Z + XZ + XY + YZ' = X'Y' + XZ + YZ'$
- E. $AB' + A'C'D' + A'B'D + A'B'CD' = B' + A'C'D'$
- F. $XZ + WY'Z' + W'YZ' + WX'Z' = XZ + WY'Z' + WXY' + W'XY + X'YZ'$
- G. $CD + AB' + AC + A'C' + A'B + C'D' = (A' + B' + C + D')(A + B + C' + D)$

2. Simplify the following Boolean expressions to the minimum number of literals (total number of appearances of all variables).

- A. $ABC + ABC' + A'B$
- B. $(A + B)(A' + B')$
- C. $A'BC + AC$
- D. $BC + B(AD + AD')$
- E. $(A + B' + AB')(AB + A'C + BC)$

3. Reduce the following expressions to the indicated number of literals (total number of appearances of all variables).

- A. $X'Y' + XYZ + X'Y$ to 3 literals
- B. $X + Y(Z + (X + Z)')$ to 2 literals
- C. $W'X(Z' + Y'Z) + X(W + W'YZ)$ to 1 literal
- D. $((A + B) + A'B')(C'D' + CD) + A'C'$ to 4 literals

4. Find the complement of the following expressions

- A. $AB' + A'B$
- B. $(V'W + X)Y + Z'$
- C. $WX(Y'Z + YZ') + W'X'(Y' + Z)(Y + Z')$
- D. $(A + B' + C)(A'B' + C)(A + B'C')$

5. Obtain the truth tables for the following expressions

- A. $(XY + Z)(Y + XZ)$
- B. $(A' + B)(B' + C)$
- C. $WXY' + WXZ' + WXZ + YZ'$

6. Convert the following truth table to switching expression (Boolean Algebra), and simplify the expression as much as possible

X	Y	Z	E
0	0	0	0
0	0	1	1
0	1	0	0
0	1	1	0
1	0	0	1
1	0	1	1
1	1	0	1
1	1	1	1

X	Y	Z	G
0	0	0	0
0	0	1	0
0	1	0	1
0	1	1	1
1	0	0	0
1	0	1	0
1	1	0	1
1	1	1	1

7. Using DeMorgan's theorem, express the function

$$F = ABC + A'C' + A'B'$$

- B. with only OR and complement operators
- C. with only AND and complement operators

Minterms & Maxterms

8. Write the truth table for the following functions, and express the functions as sum-of-minterms and product-of-maxterms

- A. $(XY + Z)(Y + XZ)$
- B. $(A' + B)(B' + C)$
- C. $WXY' + WXZ' + WXZ + YZ'$

9. Convert the following expressions into sum-of-products (minterms) and product-of-sums (maxterms)

- A. $(AB + C)(B + C'D)$
- B. $X' + X(X + Y')(Y + Z')$
- C. $(A + BC' + CD)(B' + EF)$

10. Convert the following gate diagrams into (1) switching expression, (2) truth table, (3) minterms, and (4) maxterms

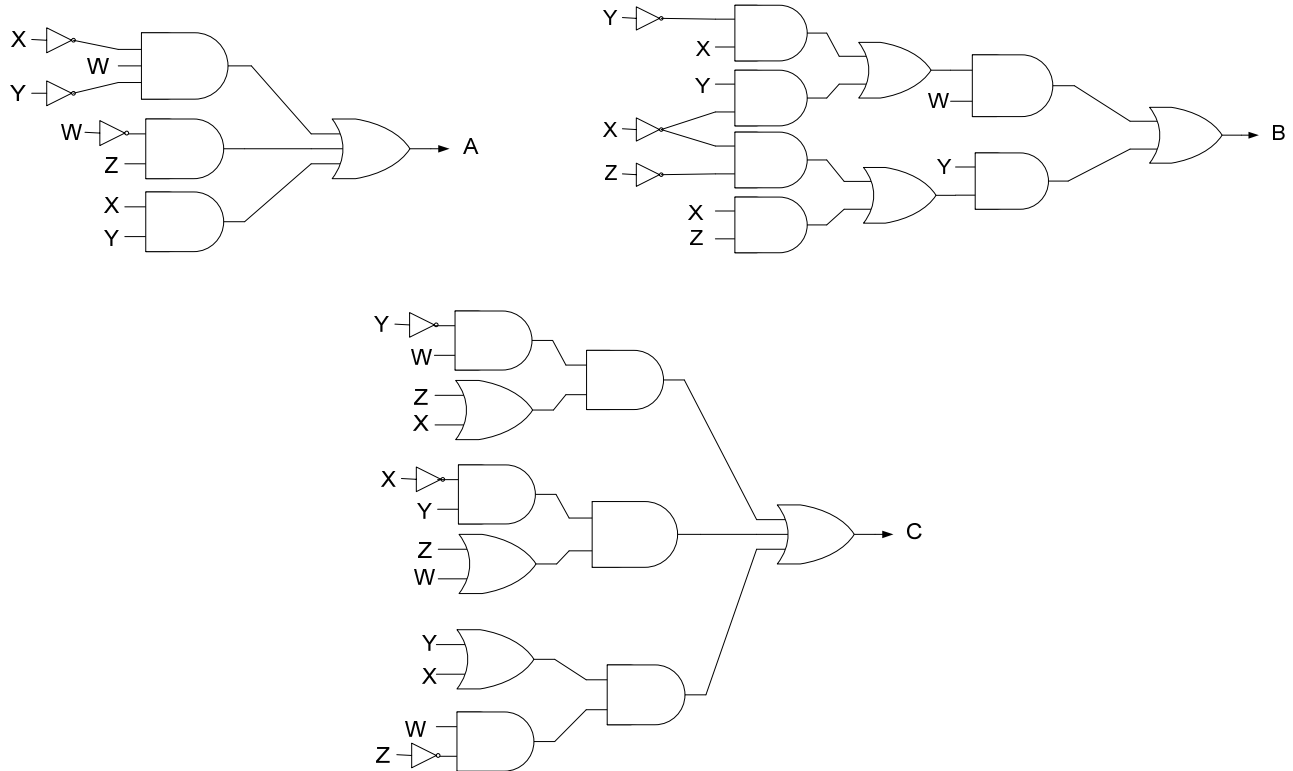

11. Simplify the following expressions in (1) sum-of-products and (2) product-of-sums forms

- A. $AC' + B'D + A'CD + ABCD$
- B. $(A' + B + D')(A + B' + C')(A' + B + D')(B + C' + D')$
- C. $(A' + B' + D)(A' + D')(A + B + D')(A + B' + C + D)$
- D. $F(A,B,C,D) = \sum m(2,3,5,7,8,10,12,13)$
- E. $F(X,W,Y,Z) = \prod M(2,10,13)$

12. For the Boolean functions given in the following truth table:

X	Y	Z	E	F	G
0	0	0	1	0	1
0	0	1	1	0	1
0	1	0	1	1	1
0	1	1	0	1	0
1	0	0	0	0	1
1	0	1	1	0	0
1	1	0	0	1	1
1	1	1	0	1	0

- A. List the minterms and maxterms of each function
- B. List the maxterms of E' , F' , and G'
- C. Write the truth tables for $E + F$ and EF
- D. List the minterms of $E + F$ and EF
- E. Express E , F and G in sum-of-products
- F. Simplify E , F and G to expressions with a minimum number of literals (either sum-of-products or products-of-sums)