



Toward Clock Skew Based Wireless Sensor Node Services

Md. Borhan Uddin

State University of New York (SUNY) Stony Brook

Claude Castelluccia

INRIA, Rhone-Alpes, France

Outline & Overview



- Clock skew
- Related Work
- Clocks on wireless sensor motes
- Our experiments for exploring
 - Unique clock skews of sensor motes
 - Temperature dependency of clock skew of sensor motes
- Usage of
 - clock skew based mote identification
 - temperature dependency property of clock skew of sensor motes
- Pros and cons of clock skew based services in WSN
- Future work and Conclusion

Clock Skew



- Rate of deviation of a device clock from the true time
- Frequency of a device's clock crystal depends on environmental factors as- temperature, humidity, EMI, vibration and type of crystal etc.

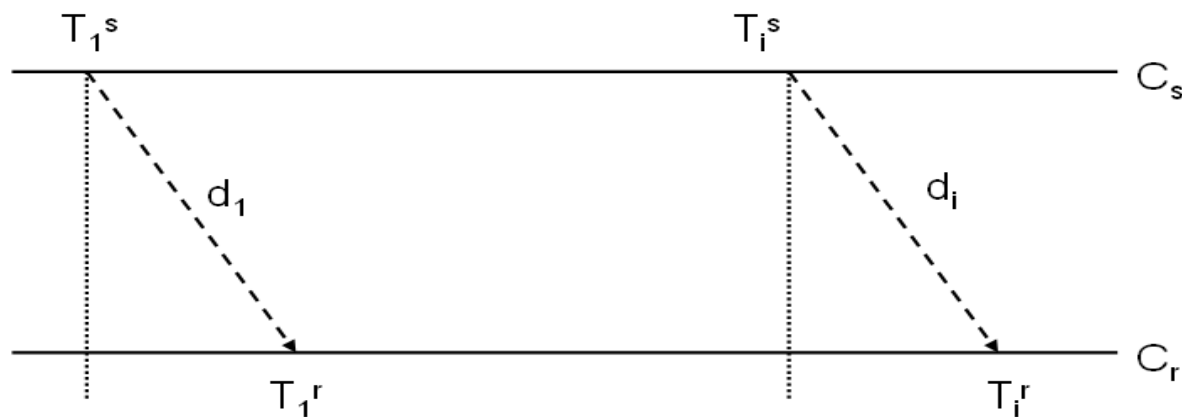

$$t_i^s = (T_i^s - T_1^s) / Hz_s$$
$$t_i^r = (T_i^r - T_1^r) / Hz_r$$
$$\tilde{o}_i = t_i^s - t_i^r$$
$$(t_i^r, \tilde{o}_i) \text{ for } i \in \{1, \dots, N\}$$

Calculate $\hat{o}(t) = \hat{\delta} \times t + \gamma$
minimizing $\frac{1}{N} \sum_{i=1}^N (\hat{o}(t_i^r) - \tilde{o}_i)$
where clock skew is $\hat{\delta}$

Related Work



- Clock skew based remote fingerprinting of hosts in computer networks [[Kohno et al., IEEE S&P 2005](#)]
- Temperature dependency of clock skew has been utilized for revealing hidden services in Tor network [[Murdoch, ACM CCS 2006](#)]
- Synchronized sampling of device's clocks produce more accurate estimation of clock skew with low resolution timestamps[[Zander et al., USENIX Security 2008](#)]

Clocks on Wireless Sensor Motes

Motes clocks are composed of-

- Hardware Components- crystal oscillators with microcontroller and hardware timer counter
- Software Components- software timer counters with different sizes and frequencies



TimerCounter	16-bit	32-bit	48-bit	64-bit
TMilli	64 seconds	48.5 days	8716.3 years	571 million years
T32kHz	2 seconds	36.4 hours	272.4 years	17.8 million years
TMicro	64 milliseconds	1.14 hour	8.5 years	557844.6 years

Rollover time for different size(width) and frequency counters in **TinyOS** implementation [48 and 64-bit non existing in TinyOS]

Experiments

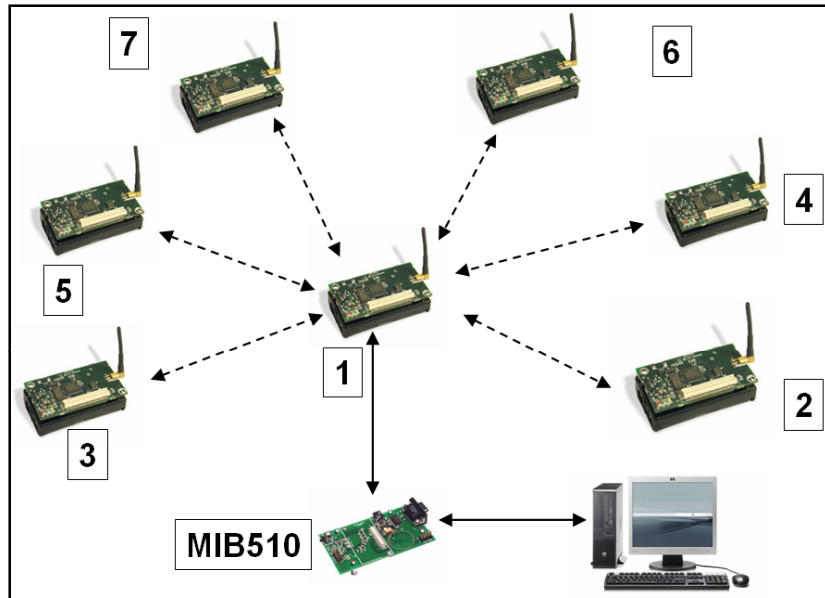

Single-hop WSN Setup

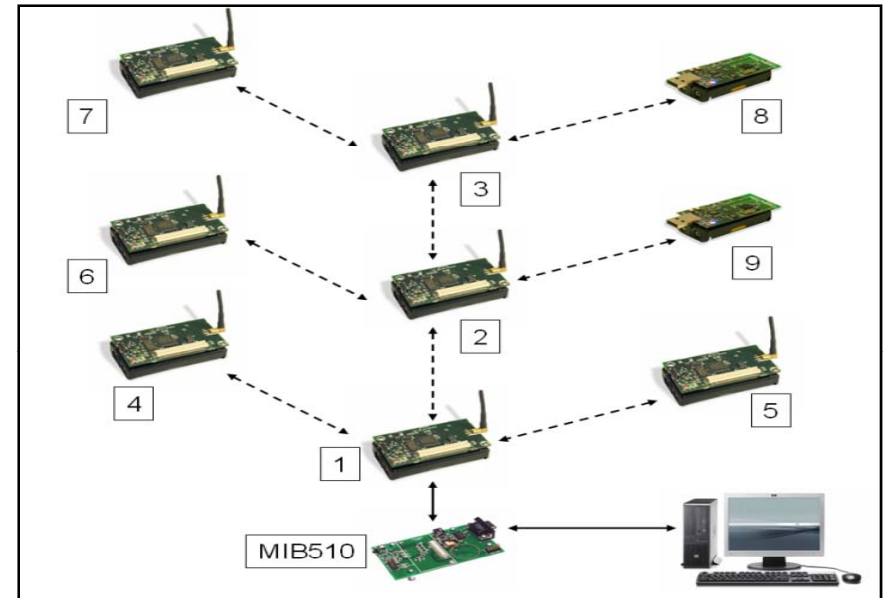

Multiple-hop WSN Setup

- Motes were programmed with **nesC TinyOS** to send synchronized timestamps to sink
- Experiments were conducted
 - for single and multi-hop WSN with homo- and hetero (**MICAz** and **TelosB**) motes
 - with different precision (Milli, 32kHz and Micro) timestamps
 - with and without varying temperature at end nodes
- Linear Time [[Dyer, SIAM J. 1983](#)] Linear Programming based approach [[Moon et al, IEEE Infocom 1999](#)] was used to calculate the skews



Different and Unique Clock skews of Motes

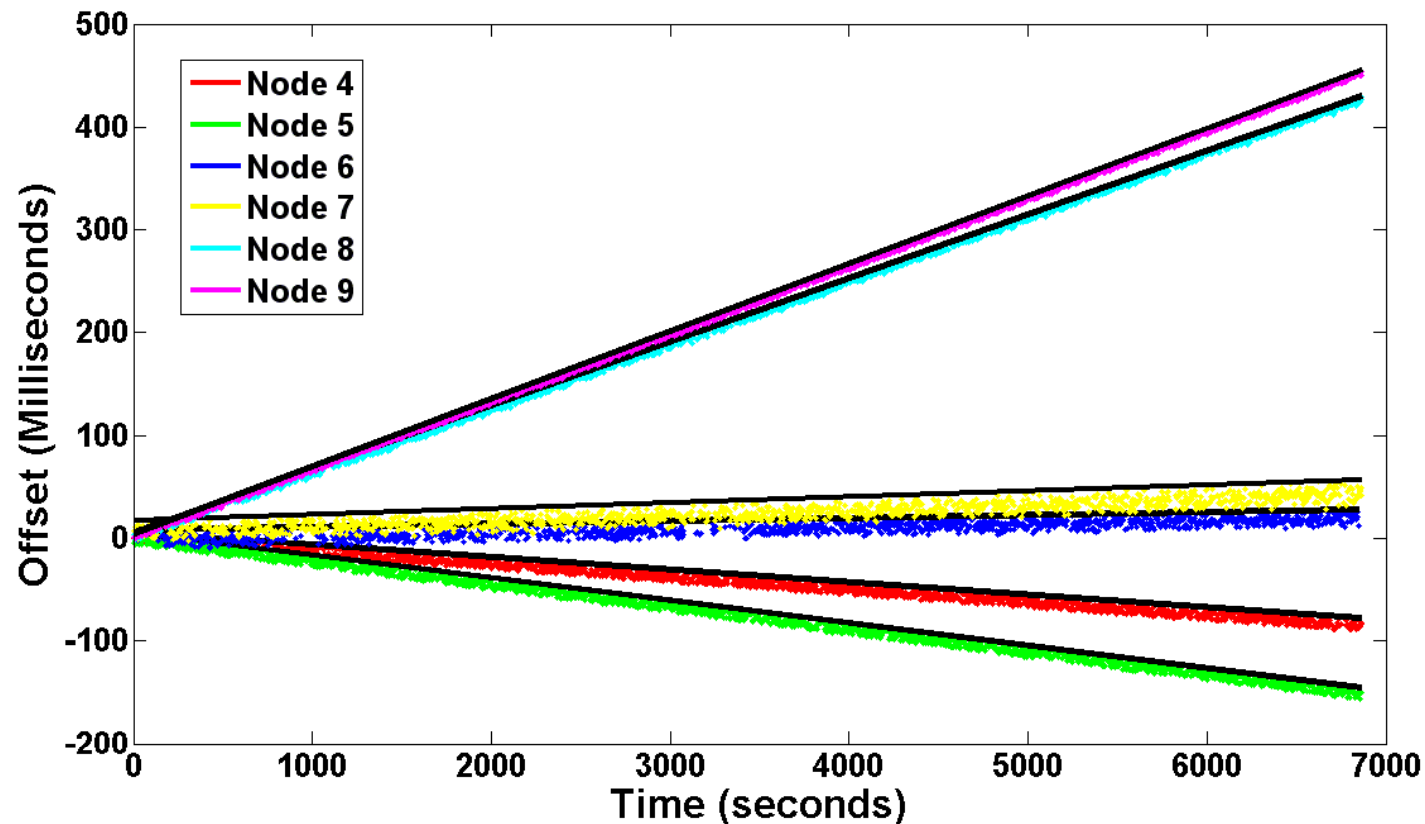

- Motes can be identified by parts per million (ppm) level clock skew
- Homogeneous and heterogeneous motes as well as individual motes can be identified

Temperature Dependency of Mote Clock Skews

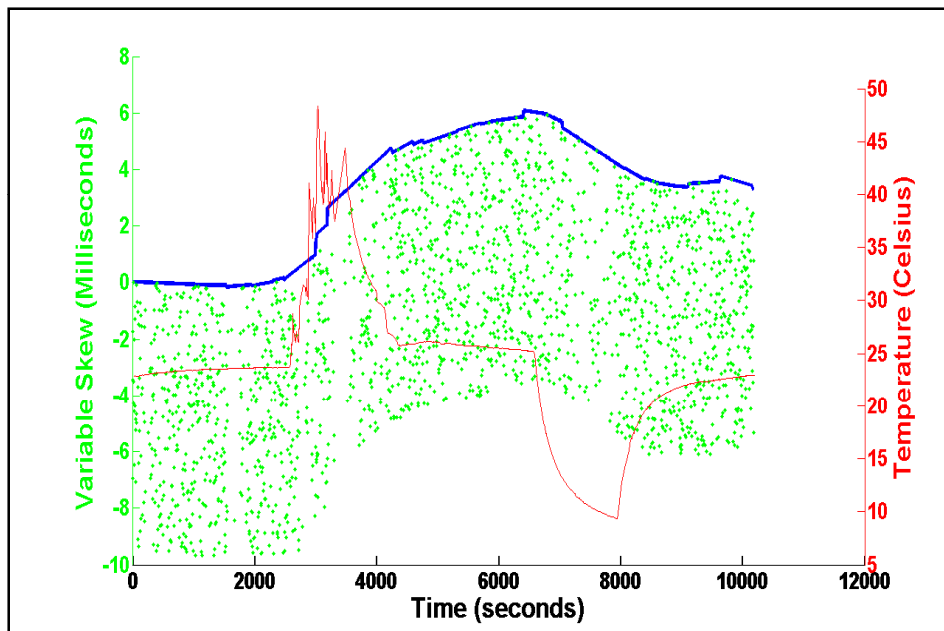

Variable Skew vs. Temperature

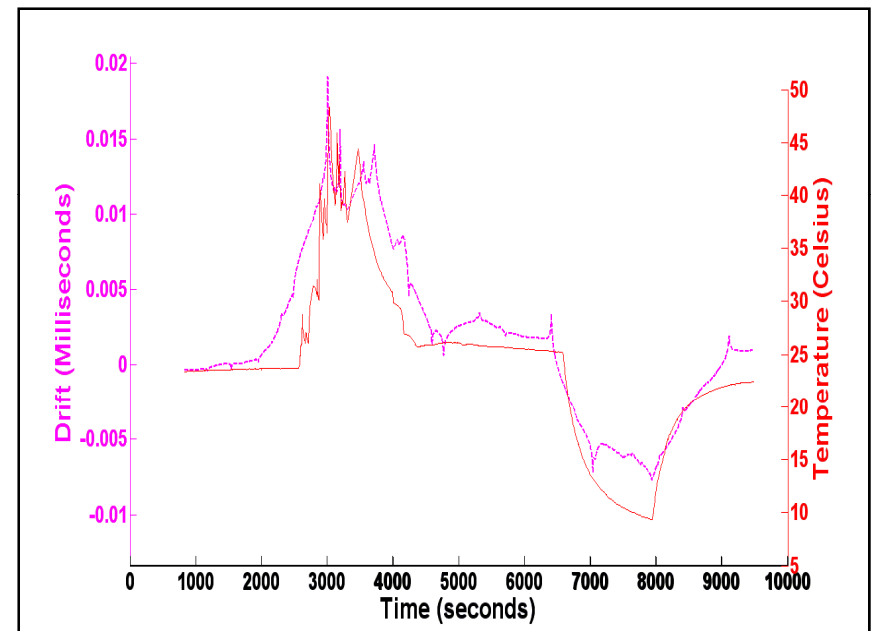

Drift vs. Temperature

- Clock skew varies with variation of temperature
- Clock **drift** (first derivative of variable clock skew) increases with the increase of temperature and decreases with the decrease of temperature

Clock Skew Based Services in WSN

- Based on Unique and different Clock skews of Motes:
 - Fingerprinting (identification) of wireless sensor motes
 - Detection of Virtual Sensor Nodes, Wormholes and Sybil Attack
- Based on temperature dependency of clock skew of Sensor Motes:
 - Malicious/malfunctioning node identification
 - Estimation of Temperature on node
 - Geolocation



Feasibility of Skew Based Services

- **Remote Monitoring Issues:** environmental factors and security
- **Thermal compensation of Clock crystals:**

Temperature Compensated Crystal Oscillators (TCXO) and Oven-Controlled Crystal Oscillators (OCXO)

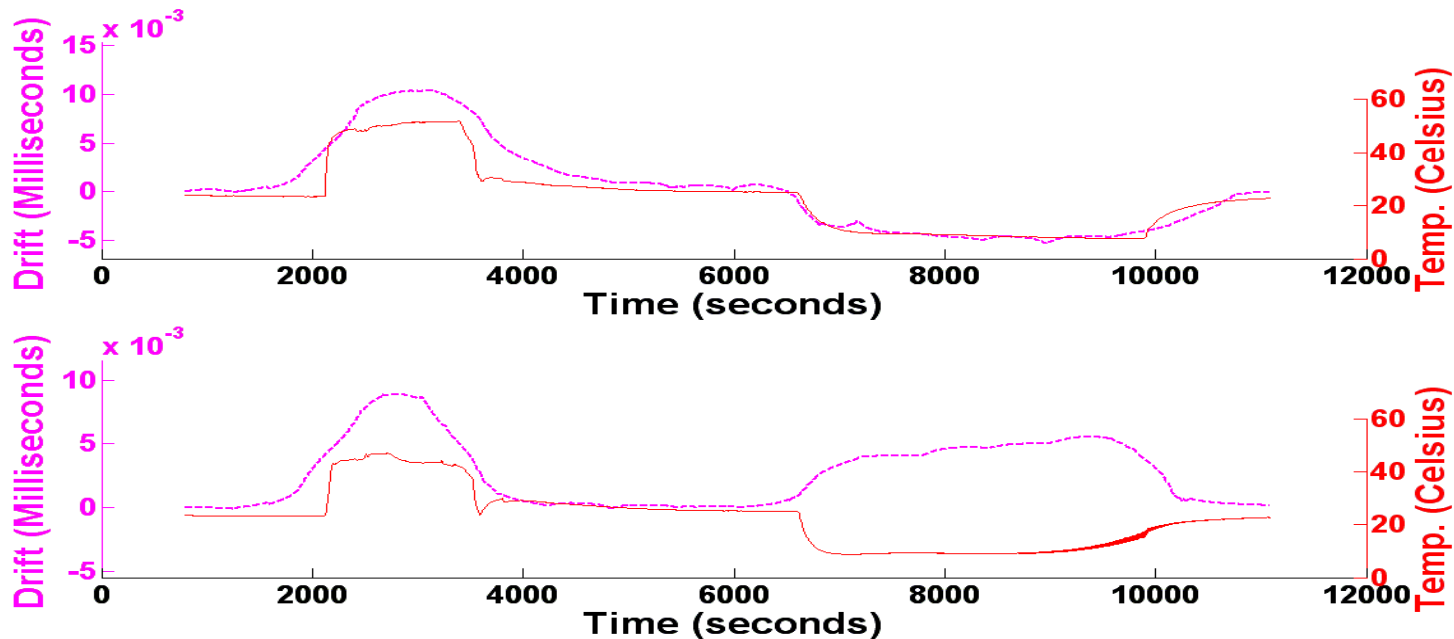

Drift of MICAz (upper) and TelosB (lower) motes vs Temperature

Feasibility (contd.)



- **Computational Issues:**
 - Window sizes for denoising and differentiating
 - Packet rate
 - Total number of packets
 - Timer counter overflow
 - Computation time of linear programming based approach
 - Drift vs temperature correlation coefficients

Conclusion and Future Work



- Clock skew can be utilized for homogeneous and heterogeneous mote identification as well as individual mote identification in WSN
- This property can be used for fingerprinting of sensor motes, protecting motes against wormhole and cybil attacks.
- Clock drift varies with variation of temperature.
- This property can be utilized for malicious/malfunctioning mote identification, estimation of temperature and geolocation
- **Future work:** Exploring feasibility and mechanism of clock skew based geolocation estimation, security aspects of clock skew based services.



Thank you!

Questions?

Please forward your questions at-
mduddin@cs.sunysb.edu