

Paper: Lessons from the Sony DRM Episode

- Increased complexity != increased security
- User experience matters
- Incentives matter
 - Music labels
 - Risk averse
 - Want to please users
 - DRM manufacturers
 - Risk tolerant
 - Want to please labels
 - User
 - License full rights
- Incentives of record label
 - Music DRM ineffective at preventing mass piracy
 - Prevent CD to CD copying
 - Limited distribution
 - Enables redundant setting
- Incentives of DRM manufacturers
 - Prevent copying
 - Build uninstall base
 - Increase value to customers
 - Control standards
 - Data harvesting
- Nobody cared about the users' interests
 - Fair user rights
 - System security
 - System reliability
 - System transparency
 - User privacy
- DRM manufacturers == malicious
 - SONY – negligible role
 - DRM users invaded user privacy
 - Harmed legal users
 - Illegal users attack
 - No prompt for user consent before uninstallation
 - Used GPL code as resource
 - Opened back door to user system
 - Restricted some legal t\righs of users
 - Violated other peoples' copyrights

- Root kit
 - Intended to hide malicious s/w running on computer
 - Anything could hide in this rootkit
 - Rootkit hid all files and processes whose names began with '\$sys\$'
 - Hunch that such a strategy was followed so that users think of it as a SYSTEM process rather than something malicious and external
 - Could have chosen something like '\$sysxcp \$' etc
- Uninstall procedure
 - Weak
 - Created directory with system services and user permissions
 - Final arguments use ActiveX
 - Install ActiveX control
 - Parameters to ActiveX control specific locations to download dll and then execute its code
 - ActiveX left on the user system with no set procedure to automatically uninstall it
- Ultimate sufferer :: user
 - Ends up paying for security breaches
- Incentive misalignment
 - Party A pays for security
 - Party B benefits
- Security Feature

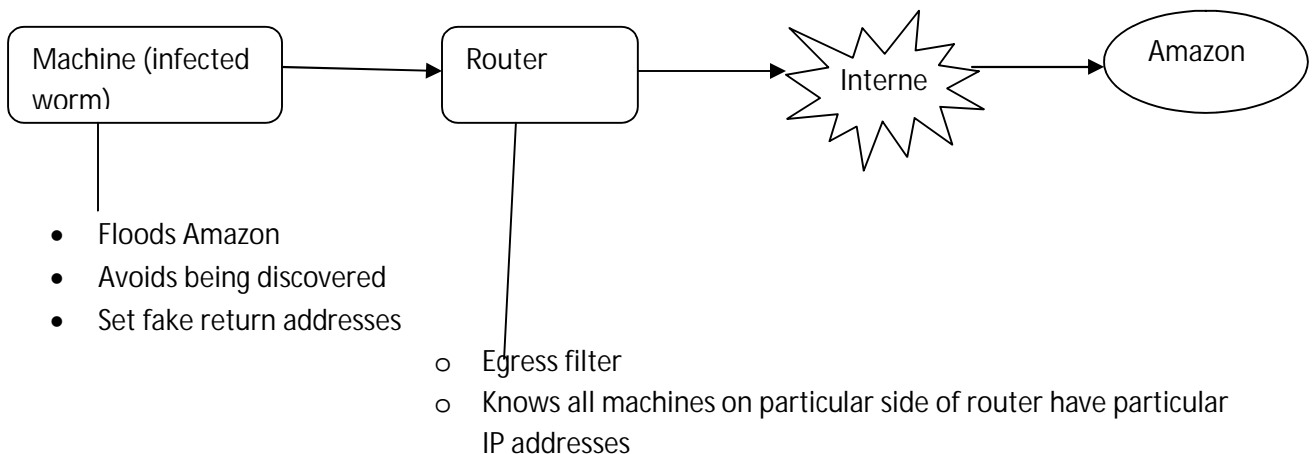

RESULT: Amazon saved but router overloaded

- ATM use
 - UK, USA
 - Users averse to using ATM
 - No human watch in ATM cubicle
 - Security through obscurity